

Operating Procedures for 10” through 24” GripTight MAX[®] High Pressure Test Plug

Thank you for choosing to use a GripTight MAX (GTMAX[®]) Test Plug. Please note that the following procedures apply to testing metallic pipes or tubes. If you are testing non-metallic pipes or tubes, please contact EST Group Customer Service prior to usage. Failure to follow the correct procedures for testing non-metallic pipes or tubes may result in injury to personnel and damage to equipment.

In order to carry out safe testing with your GripTight MAX Test Plug, the following equipment is required:

1. A calibrated torque wrench that is capable of producing the required torque
2. A deep socket or crowfoot wrench (1-5/8 inch for all plugs)
3. Pipe cap(s) or couplings with working pressure greater than or equal to the test pressure being used (see Table 1 for size).

All required test equipment is available through EST Group. All equipment and components required to maintain and refurbish GTMAX Test Plugs is available through EST Group. Contact EST Group Customer Service for information.

WARNING

- ⚠ Pressure testing is inherently dangerous. Strict adherence to these operating procedures and industry standard safety practices could prevent injury to personnel and damage to equipment.
- ⚠ All personnel must be clear of the GripTight MAX Test Plug during pressure testing. Never stand in the potential path of a GripTight MAX Test Plug during testing. Always understand and observe industry standard safe practices for distance between personnel and equipment being tested.
- ⚠ Pressures must never exceed the maximum pressure rating of any component in a system or the maximum pressure rating of the GripTight MAX Test Plug being used.
- ⚠ For safety, an incompressible liquid such as water should be used as the test medium. Residual air or gas must be displaced from the pipe prior to testing.
- ⚠ If testing pneumatically, every attempt to limit potential damage to equipment or injury to personnel must be made. The suggested test medium for pneumatic testing is nitrogen since it cannot support combustion. Testing procedures and protocol should adhere to the provisions for pneumatic testing set forth in the current ASME PCC-2 Repair of Pressure Equipment and Piping.
- ⚠ GripTight MAX Test Plugs are designed to withstand test pressure in the direction shown below. Do not use these plugs in applications that would subject the plugs to pressure in a manner that differs from the image below.

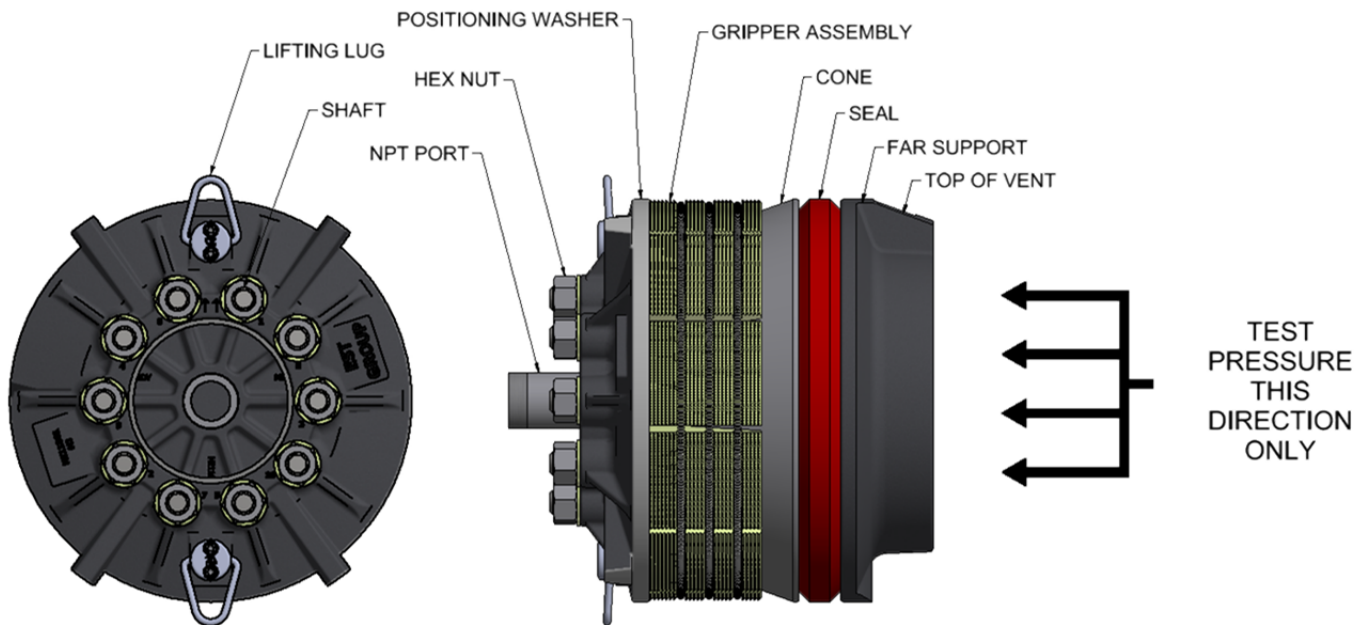

GripTight MAX High Pressure Test Plug

Questions? Contact EST Group Customer Service at any of the following locations.

**CURTISS-
WRIGHT**

EST Group

www.cw-estgroup.com

North, Central & South America

EST Group Corporate Office
2701 Township Line Road
Hatfield, PA 19440-1770 USA
P: +1.215.721.1100
+1.800.355.7044
F: +1.215.721.1101

est-info@curtisswright.com

Europe / Middle East / Africa

EST Group B.V.
Hoor 312a
2404 HL Alphen aan den Rijn
The Netherlands
P: +31.172.418841
F: +31.172.418849

est-emea@curtisswright.com

China

P +86.400.636.5077
est-china@curtisswright.cn

Singapore

P +65.3158.5052
est-asia@curtisswright.com

1. Test Preparation

- 1.1. Fully read and understand these operating procedures. Pressure testing is inherently dangerous and must be performed as safely as possible. If any instruction contained in this document is unclear, STOP and contact EST Group Customer Service.
- 1.2. Following these procedures and industry standard safe practices may prevent injury to personnel and damage to property.
- 1.3. Read these instructions prior to every test. Be familiar with and use applicable Human Performance Tools before, during, and after every test.
- 1.4. Hydrostatic testing is preferred over pneumatic testing due to safety concerns. Displace as much air or gas as possible prior to conducting a hydrostatic test.
- 1.5. If any instruction contained in these operating procedures contradicts a site specific guideline or procedure: STOP and contact EST Group Customer Service for guidance.

Test pressure MUST NOT exceed the maximum pressure rating of the lowest rated component under test.

The test pressure MUST NOT exceed the rated pressure of the plug.

Test pressure MUST NOT exceed 80% of specified minimum yield stress for host pipe, tube, or equipment.

Examples of Human Performance Tools

Pre-Job Briefing
 Two-Minute Drill
 Three-Way Communication
 Phonetic Alphabet
 S.T.A.R. (Stop-Think-Act-Review)
 Procedure Use and Adherence
 Place Keeping (Circle Slash)
 Flagging / Operational Barriers
 Self-Checking
 Independent Verification
 Concurrent Verification
 First Check
 STOP When Unsure
 Peer Checking
 Post-Job Review

WARNING

⚠ Contact EST Group Customer Service if the test pressure required exceeds the maximum plug rating or is in excess of 80% of specified minimum yield stress for host pipe, tube, or equipment.

2. Equipment Inspection and Preparation

Perform the following steps prior to performing your pressure test.

Step/Action	Additional Action/Information/Result
2.1. Visually inspect the plug for worn or damaged components. Replace as needed.	<ul style="list-style-type: none"> • The tapered surface between the Cone and Grippers must be free of friction producing dirt or corrosion. • Apply a light lubricant such as Molykote® DX or SAE 10W motor oil to the tapered surface of the Cone. Wipe away any excess lubricant from components making sure to leave an ample amount on tapered cone face and mating surface of gripper back. Lubricant <u>must not</u> be on seal.
2.2. Lubricate surface of the Tapered Cone.	
2.3. Inspect or lubricate the underside of the positioning washer where the grippers slide.	<ul style="list-style-type: none"> • The Seal must not have excessive deformations, cuts or scores.

Questions? Contact EST Group Customer Service at any of the following locations.

**CURTISS -
WRIGHT**

EST Group

www.cw-estgroup.com

North, Central & South America

EST Group Corporate Office
 2701 Township Line Road
 Hatfield, PA 19440-1770 USA
 P: +1.215.721.1100
 +1.800.355.7044
 F: +1.215.721.1101
est-info@curtisswright.com

Europe / Middle East / Africa

EST Group B.V.
 Hoorn 312a
 2404 HL Alphen aan den Rijn
 The Netherlands
 P: +31.172.418841
 F: +31.172.418849
est-emea@curtisswright.com

China

P +86.400.636.5077
est-china@curtisswright.cn

Singapore

P +65.3158.5052
est-asia@curtisswright.com

Step/Action	Additional Action/Information/Result								
2.4. Liberally spread antiseize over both sides of the Hardened Washers and on the threads of the Shaft.	<p style="text-align: center;">CAUTION</p> <p>⚠ Failure to properly lubricate Shaft thread and Washer surfaces may result in unsafe operating conditions or plug leakage.</p>								
2.5. Verify there is no debris in the gripper teeth; clean as needed.									
2.6. Tighten the Hex Nuts so the Grippers move freely to the end of the Tapered Cone surface.	<table border="1" style="width: 100%; border-collapse: collapse;"> <thead> <tr> <th style="background-color: #4F81BD; color: white; text-align: center;">If</th> <th style="background-color: #4F81BD; color: white; text-align: center;">then</th> </tr> </thead> <tbody> <tr> <td>Grippers move freely to end of the tapered Cone surfaces,</td> <td>Loosen the Hex Nuts back to its/their original position and go to the next step.</td> </tr> <tr> <td>Grippers do not fully retract,</td> <td>If required, remove any light rust, residue or corrosion on the cone face, gripper backs and tops and underside of positioning washer using a Scotch Brite Pad or pad of equivalent quality. Re-lubricate gripper backs, tops and tapered cone surface using a lubricant such as Molykote® DX or SAE 10W motor oil. Wipe away any excess lubricant from components making sure to leave an ample amount on Tapered Cone face and mating surface of gripper back. If grippers still do not fully retract and nuts cannot be easily advanced, do not use this plug for testing. Contact EST Group Customer Service for assistance.</td> </tr> <tr> <td>The Hex Nuts cannot easily be tightened to allow full gripper expansion</td> <td>Do not use this plug for testing. Contact EST Group Customer Service for assistance.</td> </tr> </tbody> </table>	If	then	Grippers move freely to end of the tapered Cone surfaces,	Loosen the Hex Nuts back to its/their original position and go to the next step.	Grippers do not fully retract,	If required, remove any light rust, residue or corrosion on the cone face, gripper backs and tops and underside of positioning washer using a Scotch Brite Pad or pad of equivalent quality. Re-lubricate gripper backs, tops and tapered cone surface using a lubricant such as Molykote® DX or SAE 10W motor oil. Wipe away any excess lubricant from components making sure to leave an ample amount on Tapered Cone face and mating surface of gripper back. If grippers still do not fully retract and nuts cannot be easily advanced, do not use this plug for testing. Contact EST Group Customer Service for assistance.	The Hex Nuts cannot easily be tightened to allow full gripper expansion	Do not use this plug for testing. Contact EST Group Customer Service for assistance.
If	then								
Grippers move freely to end of the tapered Cone surfaces,	Loosen the Hex Nuts back to its/their original position and go to the next step.								
Grippers do not fully retract,	If required, remove any light rust, residue or corrosion on the cone face, gripper backs and tops and underside of positioning washer using a Scotch Brite Pad or pad of equivalent quality. Re-lubricate gripper backs, tops and tapered cone surface using a lubricant such as Molykote® DX or SAE 10W motor oil. Wipe away any excess lubricant from components making sure to leave an ample amount on Tapered Cone face and mating surface of gripper back. If grippers still do not fully retract and nuts cannot be easily advanced, do not use this plug for testing. Contact EST Group Customer Service for assistance.								
The Hex Nuts cannot easily be tightened to allow full gripper expansion	Do not use this plug for testing. Contact EST Group Customer Service for assistance.								
2.7. Clean and dry the inside of the pipe.	<ul style="list-style-type: none"> All moisture, debris, and excessive scale must be removed from the pipe ID to ensure a proper seal is established during the pressure test. 								
2.8. Verify that the pipe size and schedule stamped on the GripTight MAX Test Plug is equivalent to the size of the pipe you are testing, or that the inside diameter (ID) of the equipment being tested is within the ID operating range for the GripTight MAX Test Plug being used.	<div style="border: 1px solid black; padding: 5px; background-color: #f0f0f0;"> <p>NOTE: Schedule 5 wall thickness pipe, or tubes with a wall thickness less than equivalent Schedule 10/10S pipe, must have an OD restraint. Contact EST Customer Service for information.</p> </div> <ul style="list-style-type: none"> See Table 1 and Table 2 for the Functional ID Operating Range for GripTight MAX Test Plugs. 								
2.9. Verify that the equipment to be tested is prepared before performing the test. Make sure all applicable safety procedures are observed and followed, e.g. Lock-Out Tag-Out, work permits, correct components is being tested, etc.	<p style="text-align: center;">CAUTION</p> <p>⚠ Special caution must be taken when applying lubricant and handling the GripTight MAX Test Plug. The lubricant must not come in contact with the Seal, the Gripper Teeth, or the inside of the pipe or tube.</p>								

Questions? Contact EST Group Customer Service at any of the following locations.



EST Group

www.cw-estgroup.com

North, Central & South America

EST Group Corporate Office
2701 Township Line Road
Hatfield, PA 19440-1770 USA
P: +1.215.721.1100
+1.800.355.7044
F: +1.215.721.1101

est-info@curtisswright.com

Europe / Middle East / Africa

EST Group B.V.
Hoor 312a
2404 HL Alphen aan den Rijn
The Netherlands
P: +31.172.418841
F: +31.172.418849

est-emea@curtisswright.com

China

P +86.400.636.5077
est-china@curtisswright.cn

Singapore

P +65.3158.5052
est-asia@curtisswright.com

3. Installing and Using the Safety Gag or Pipe Restraint

Safety Gags are strongly recommended for every application as they enhance the safety of the test system configuration. Perform the following steps if you are using a Safety Gag.

A Pipe Restraint is recommended for thin walled pipes or tubes (wall thickness equivalent to Schedule 10/10S) and required on pipes or tubes with walls thinner than Schedule 10/10S.

If a Safety Gag or Pipe Restraint is not being used, skip to Section 4: Performing the Pressure Test.

Step/Action	Additional Action/Information/Result	
	If	Then
3.1. Install Safety Gag Pipe Clamps or Pipe Restraints onto pipe being tested. If required, the safety chains may be placed between the Pipe Clamps or the Pipe Restraints. This configuration is acceptable as long as the placement of the chains does not prevent the Safety Gag or Pipe Restraint from tightening securely on to the outside of the pipe or tube.	Using a Safety Gag	Install the Safety Gag pipe clamps onto the pipe.
	Using a Pipe Restraint with or without Safety Chains	Position the Pipe Restraint over the area where the GripTight MAX Test Plug is installed.
<p>CAUTION</p> <p>⚠ GripTight MAX Test Plug Seals and Grippers are energized by test pressure. During pressurization, the Shaft(s) may move slightly. This is normal and expected. A small amount of slack in the Safety Chain(s) is required for this movement and energization to occur.</p>		
3.2. Tighten the bolts enough to prevent the Safety Gag or Pipe Restraint from moving. The Safety Gag or Pipe Clamp should not be able to rotate, slide, or move when pushed or pulled.		
3.3. Insert GripTight MAX Test Plug into the equipment to be tested.		
3.4. Follow remaining GripTight MAX Test Plug installation procedure as per the steps in Section 4: Performing the Pressure Test.		
3.5. Slip the Link(s) over the Shaft(s) before introducing test medium or test pressure. Do not place the Link(s) under the GripTight MAX Test Plug Hex Nut(s) or over the center port.		



Note: In some cases to make the clamp tight, the chain or chains need to be outside the tangs



Questions? Contact EST Group Customer Service at any of the following locations.

**CURTISS-
WRIGHT**

EST Group

www.cw-estgroup.com

North, Central & South America

EST Group Corporate Office
2701 Township Line Road
Hatfield, PA 19440-1770 USA
P: +1.215.721.1100
+1.800.355.7044
F: +1.215.721.1101
est-info@curtisswright.com

Europe / Middle East / Africa

EST Group B.V.
Hoor 312a
2404 HL Alphen aan den Rijn
The Netherlands
P: +31.172.418841
F: +31.172.418849
est-emea@curtisswright.com

China

P +86.400.636.5077
est-china@curtisswright.cn

Singapore

P +65.3158.5052
est-asia@curtisswright.com

4. Performing the Pressure Test

Perform the following steps to perform a pressure test with the GripTight MAX Test Plug.

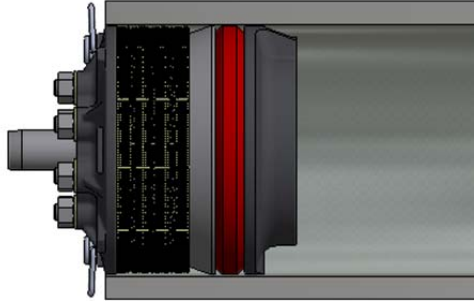
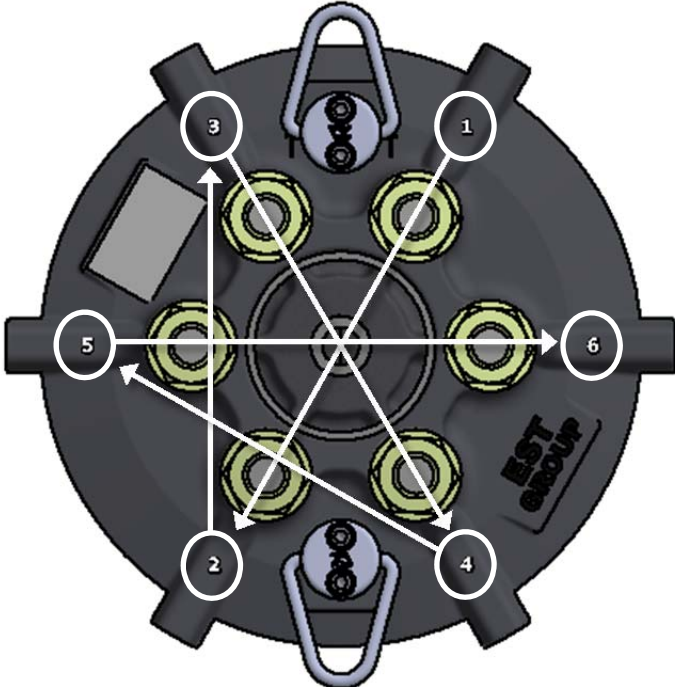
Step/Action	Additional Action/Information/Result				
<p>4.1. Place the GripTight MAX Test Plug inside the pipe. The GripTight MAX Test Plug must be able to fit with the full length of the Grippers inside the pipe. Ideally, the plug should be inserted until the positioning washer contacts the face of the equipment being tested.</p>					
<p>4.2. If testing in seam-welded pipe, position the Grippers so that the weld seam is between two Gripper segments.</p>	<div style="border: 1px solid red; padding: 5px;"> <p style="text-align: center;">Warning</p> <p>⚠ It is sometimes necessary to remove the weld seam in the area where the GripTight MAX Test Plug is being installed. Carefully machine or grind the weld bead in the area of the test plug.</p> </div> <div style="border: 1px solid gray; padding: 5px; margin-top: 5px;"> <p>Note: The inside of the tube or pipe must be clean, dry, and free of rust, scale, or debris.</p> </div>				
<p>4.3. Center the GripTight MAX Test Plug within the pipe and hand tighten the Hex Nuts until the test plug has gripped the pipe ID.</p>	<table border="1" style="width: 100%; border-collapse: collapse;"> <thead> <tr> <th style="background-color: #4a7ebb; color: white;">If</th> <th style="background-color: #4a7ebb; color: white;">Then</th> </tr> </thead> <tbody> <tr> <td style="text-align: center;">Using GripTight MAX Test Plugs horizontally,</td> <td style="text-align: center;">Tighten the bottom Hex Nuts first to help center the GripTight MAX Test Plug within the pipe.</td> </tr> </tbody> </table>	If	Then	Using GripTight MAX Test Plugs horizontally,	Tighten the bottom Hex Nuts first to help center the GripTight MAX Test Plug within the pipe.
If	Then				
Using GripTight MAX Test Plugs horizontally,	Tighten the bottom Hex Nuts first to help center the GripTight MAX Test Plug within the pipe.				
<div style="border: 1px solid gray; padding: 5px;"> <p>Note: Slight wiggling of the plug may allow for further hand tightening of the Hex Nut(s).</p> </div>					
<p>4.4. Use a star pattern to incrementally tighten the Hex Nuts. Numbers on the positioning washer provide a suggested tightening sequence. Repeat torque sequence until desired torque has been applied.</p>					

Questions? Contact EST Group Customer Service at any of the following locations.

**CURTISS-
WRIGHT**

EST Group

www.cw-estgroup.com

North, Central & South America

EST Group Corporate Office
2701 Township Line Road
Hatfield, PA 19440-1770 USA
P: +1.215.721.1100
+1.800.355.7044
F: +1.215.721.1101
est-info@curtisswright.com

Europe / Middle East / Africa

EST Group B.V.
Hoor 312a
2404 HL Alphen aan den Rijn
The Netherlands
P: +31.172.418841
F: +31.172.418849
est-emea@curtisswright.com

China

P +86.400.636.5077
est-china@curtisswright.cn

Singapore

P +65.3158.5052
est-asia@curtisswright.com

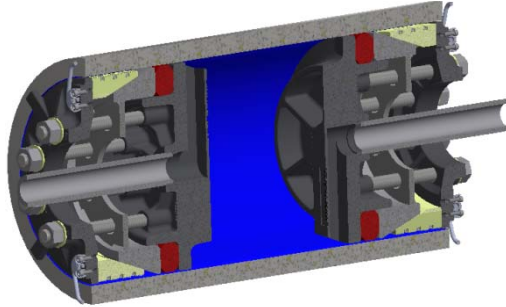
Step/Action	Additional Action/Information/Result
<p>4.5. Tighten the Hex Nut(s) with a calibrated torque wrench and an appropriately sized crowfoot wrench or deep socket. Deep Sockets are recommended for Multi-Shaft GripTight MAX Test Plugs. See Table 1 for nominal and maximum installation torques.</p>	<p style="text-align: center;">CAUTION</p> <ul style="list-style-type: none"> ⚠ The torque wrench being used must be calibrated to ensure that the correct amount of torque is being applied. An un-calibrated torque wrench may cause the operator to tighten the Hex Nut(s) either too much or too little. This may result in unsafe operating conditions or damage to the test plug. ⚠ Some crowfoot wrenches may not be able to apply the required amount of torque for some GripTight MAX Test Plugs. Before attempting to install, make sure the equipment being used is of adequate strength for the application. Using an insufficiently strong crowfoot wrench may cause injury to personnel or damage to the GripTight MAX Test Plug. ⚠ Failure to apply at least the nominal installation torque from Table 1 may result in unsafe operation of the plug. ⚠ If a crowfoot wrench is used, ensure wrench is used at a 90° angle relative to the handle of the torque wrench. Failure to do so can result in significant and dangerous over-torque.
<p>4.6. If a Safety Gag or Pipe Restraint is being used, slip the Link(s) over the Shaft(s) before proceeding. The Link(s) should not be placed under the Hex Nut(s) or over the center port.</p>	
<p>4.7. Install the pressure source leak tight. Use of a hose whip restraint is very strongly recommended. Inspect all connections to ensure they are leak tight.</p>	<ul style="list-style-type: none"> • For GripTight MAX Test Plugs not being used to pressurize or vent the system, install a pipe cap with a pressure rating that is greater than or equal to the maximum test pressure being used. <p style="text-align: center;">CAUTION</p> <ul style="list-style-type: none"> ⚠ Before proceeding, inspect the unit / component under test to ensure every component is in the correct configuration. This includes checking to make sure all GripTight MAX Test Plugs being used have been properly installed.
<p>4.8. Fill the pipe with test medium.</p>	 <p style="text-align: center;">Position A Position B</p> <ul style="list-style-type: none"> • Check for any leaks while filling. • If using a multiple GTMAX test plugs, fill the pipe or tube being tested through GTMAX Test Plug in position B (the Fill position) until test medium flows steadily out of GTMAX Test Plug in position A (the Vent position). • If not using fill and vent plugs, displace residual gases from the test system by opening the system at its highest point.

Questions? Contact EST Group Customer Service at any of the following locations.

**CURTISS -
WRIGHT**

EST Group

www.cw-estgroup.com

North, Central & South America

EST Group Corporate Office
2701 Township Line Road
Hatfield, PA 19440-1770 USA
P: +1.215.721.1100
+1.800.355.7044
F: +1.215.721.1101
est-info@curtisswright.com

Europe / Middle East / Africa

EST Group B.V.
Hoor 312a
2404 HL Alphen aan den Rijn
The Netherlands
P: +31.172.418841
F: +31.172.418849
est-emea@curtisswright.com

China

P +86.400.636.5077
est-china@curtisswright.cn

Singapore

P +65.3158.5052
est-asia@curtisswright.com

Step/Action	Additional Action/Information/Result
<p>4.9. Perform the pressure test.</p> <p>4.10. Check for leaks. A drop in pressure may not necessarily indicate a leak, as the GripTight MAX Test Plugs require some time to “settle” while pressure is applied and the testing is being performed.</p>	<ul style="list-style-type: none"> • Slowly introduce the test pressure. TEST PRESSURE MUST NEVER EXCEED THE MAXIMUM PRESSURE RATING OF ANY COMPONENT IN THE SYSTEM UNDER TEST. TEST PRESSURE MUST NEVER EXCEED THE MAXIMUM PRESSURE RATING OF THE GRIPTIGHT MAX TEST PLUG BEING USED. • Imperfections within the pipe being tested may cause small leaks. • Seam welded pipes occasionally require some weld bead to be removed. If the pipe is seam-welded and leaking persists after additional tightening, remove the weld bead in the area where the GripTight MAX Test Plug seal is installed. • If leaks persist, additional tightening of the Hex Nuts may be required. RELEASE ALL TEST PRESSURE before making adjustments to the GTMAX Test Plug. • Do not exceed the maximum torque for the GripTight MAX Test Plug. See Table 1 for torque values.
<p>4.11. Verify that GripTight MAX Test Plug movement is within specified limits.</p> <div data-bbox="105 766 673 997" style="border: 1px solid red; padding: 5px;"> <p style="text-align: center;">Warning</p> <p>⚠ Never re-torque the hex nut(s) while the plug is pressurized. This is unsafe and can cause damage to the GripTight MAX Test Plug.</p> <p>⚠ Release all pressure prior to adjusting GripTight MAX Test Plug torque.</p> </div>	<ul style="list-style-type: none"> • For Multi-Shaft GripTight MAX Test Plugs, movement up to 0.50” (13 mm) is acceptable. If plug movement exceeds the acceptable amount, immediately release all pressure and remove the GripTight MAX Test Plug. • Examine the GripTight MAX Test Plug components for wear. Pay particular attention to the condition of the Grippers. Replace parts as necessary. • Reinstall the GripTight MAX Test Plug, following all instructions provided. Increase the installation torque used. Do not exceed the maximum torque rating for the plug.
<p>4.12. Gradually release all pressure from the system once the test is completed.</p> <div data-bbox="105 1165 673 1417" style="border: 1px solid red; padding: 5px;"> <p style="text-align: center;">Warning</p> <p>⚠ Incrementally loosen Hex Nuts on multi-shaft plugs using the same star pattern as installation. Failure to do so may over stress the shafts and nuts and cause deformation or damage.</p> </div>	<div data-bbox="698 997 1536 1092" style="border: 1px solid gray; padding: 5px;"> <p>Note: If excessive Shaft movement persists after using the maximum GripTight MAX installation torque, stop the test, release all test pressure, and contact EST Group customer Service for technical assistance.</p> </div> <ul style="list-style-type: none"> • If using a GripTight MAX plugs in the Vent/Fill positions, to recover test medium, apply low pressure air to plug in Position A (see Section 4.8 reference). • Loosen the Hex Nut(s), remove the GripTight MAX Test Plug from the pipe and then inspect the GripTight MAX Test Plug for any deformation or damage. • If the plug is difficult to remove, wait for the seal to relax (up to 2-3 minutes) and a gentle wiggle of the shafts or tap on the positioning washer, will help.
<p style="text-align: center;">Warning</p> <p>⚠ Some test medium may remain inside the pipe after a hydrostatic test has been conducted. Caution must be taken when loosening Hex Nuts and removing GripTight MAX Test Plugs to prevent unsafe conditions from occurring during removal, e.g. water spills onto a catwalk creating slippery conditions.</p>	

Questions? Contact EST Group Customer Service at any of the following locations.

**CURTISS -
WRIGHT**

EST Group

www.cw-estgroup.com

North, Central & South America

EST Group Corporate Office
2701 Township Line Road
Hatfield, PA 19440-1770 USA
P: +1.215.721.1100
+1.800.355.7044
F: +1.215.721.1101

est-info@curtisswright.com

Europe / Middle East / Africa

EST Group B.V.
Hoor 312a
2404 HL Alphen aan den Rijn
The Netherlands
P: +31.172.418841
F: +31.172.418849

est-emea@curtisswright.com

China

P +86.400.636.5077
est-china@curtisswright.cn

Singapore

P +65.3158.5052
est-asia@curtisswright.com

5. Storage

- Prior to storing, clean and dry the GripTight MAX Test Plug. Do not allow the Seal to come in contact with any cleaning chemicals or solvents. Exposure to these chemicals may damage the Seal.
- Ensure the gripper teeth are free of dirt and debris. Clean as needed.
- Re-lubricate the Shaft threads and between the Hex Nuts and mating surface as previously described in Section 2: Equipment Inspection and Preparation.
- Store the GripTight MAX Test Plug in an area out of direct exposure to sun or ultraviolet (UV) light. Do not store in an area where it will be subjected to heat in excess of 180°F (82°C). Excessive heat or UV light exposure will damage and prematurely degrade the Seal(s).
- For additional protection, the GTMAX should be stored in a in a plastic bag or wrap.
- Store these instructions with each GripTight MAX Test Plug.

Table 1: GripTight MAX Test Plug Information

Part Number	Pipe Size	Pipe Schedule	Plug OD		Functional I.D. Range				Maximum Test Pressure		Installation Torque				NPT Size
					(in)		(mm)				FT-LBS		N-m		
			(in)	(mm)	Min	Max	Min	Max	(PsiG)	(BarG)	Nominal	Max	Nominal	Max	
GTMAX-10P5	10	5	10.32	262.1	10.42	10.88	264.7	276.4	3000	207	180	325	244	441	1" M
GTMAX-10P10	10	10S	10.24	260.1	10.34	10.80	262.6	274.3	3000	207	180	325	244	441	1" M
GTMAX-10P20	10	20	10.07	255.8	10.17	10.63	258.3	270.0	3000	207	180	325	244	441	1" M
GTMAX-10P30	10	30	9.96	253.0	10.06	10.52	255.5	267.2	3000	207	180	325	244	441	1" M
GTMAX-10P40	10	40/STD	9.84	249.9	9.94	10.40	252.5	264.2	3000	207	180	325	244	441	1" M
GTMAX-10P60	10	XS/60	9.57	243.1	9.67	10.13	245.6	257.3	5000	345	180	325	244	441	1" M
GTMAX-10P80	10	80	9.38	238.3	9.48	9.94	240.8	252.5	5000	345	180	325	244	441	1" M
GTMAX-10P100	10	100	9.13	231.9	9.23	9.69	234.4	246.1	5000	345	180	325	244	441	1" M
GTMAX-12P10	12	10S/5	12.20	309.9	12.30	12.76	312.4	324.1	3000	207	180	325	244	441	1" M
GTMAX-12P20	12	20	12.07	306.6	12.17	12.63	309.1	320.8	3000	207	180	325	244	441	1" M
GTMAX-12P30	12	30	11.91	302.5	12.01	12.47	305.1	316.7	3000	207	180	325	244	441	1" M
GTMAX-12P40	12	40/STD	11.82	300.2	11.92	12.38	302.8	314.5	3000	207	180	325	244	441	1" M
GTMAX-12PXS	12	XS	11.57	293.9	11.67	12.13	296.4	308.1	5000	345	180	325	244	441	1" M
GTMAX-12P60	12	60	11.45	290.8	11.55	12.01	293.4	305.1	5000	345	180	325	244	441	1" M
GTMAX-12P80	12	80	11.19	284.2	11.29	11.75	286.8	298.5	5000	345	180	325	244	441	1" M
GTMAX-12P100	12	100	10.88	276.4	10.98	11.44	278.9	290.6	5000	345	180	325	244	441	1" M
GTMAX-12P120	12	120/XXS	10.57	268.5	10.67	11.13	271.0	282.7	5000	345	180	325	244	441	1" M
GTMAX-12P140	12	140	10.32	262.1	10.42	10.88	264.7	276.4	6000	414	180	325	244	441	1" M
GTMAX-12P160	12	160	9.96	253.0	10.06	10.52	255.5	267.2	6000	414	180	325	244	441	1" M
GTMAX-14P5	14	5	13.50	342.9	13.60	14.06	345.4	357.1	3000	207	180	325	244	441	1" M
GTMAX-14P10S	14	10S	13.44	341.4	13.54	14.00	343.9	355.6	3000	207	180	325	244	441	1" M
GTMAX-14P10	14	10	13.31	338.1	13.41	13.87	340.6	352.3	3000	207	180	325	244	441	1" M
GTMAX-14P20	14	20	13.20	335.3	13.30	13.76	337.8	349.5	3000	207	180	325	244	441	1" M
GTMAX-14P30	14	STD/30	13.07	332.0	13.17	13.63	334.5	346.2	3000	207	180	325	244	441	1" M
GTMAX-14P40	14	40	12.94	328.7	13.04	13.50	331.2	342.9	5000	345	180	325	244	441	1" M
GTMAX-14PXS	14	XS	12.82	325.6	12.92	13.38	328.2	339.9	5000	345	180	325	244	441	1" M

Questions? Contact EST Group Customer Service at any of the following locations.

**CURTISS-
WRIGHT**

EST Group

www.cw-estgroup.com

North, Central & South America

EST Group Corporate Office

2701 Township Line Road

Hatfield, PA 19440-1770 USA

P: +1.215.721.1100

+1.800.355.7044

F: +1.215.721.1101

est-info@curtisswright.com

Europe / Middle East / Africa

EST Group B.V.

Hoor 312a

2404 HL Alphen aan den Rijn

The Netherlands

P: +31.172.418841

F: +31.172.418849

est-emea@curtisswright.com

China

P +86.400.636.5077

est-china@curtisswright.cn

Singapore

P +65.3158.5052

est-asia@curtisswright.com

Part Number	Pipe Size	Pipe Schedule	Plug OD		Functional I.D. Range				Maximum Test Pressure		Installation Torque				NPT Size
					(in)		(mm)				FT-LBS		N-m		
			(in)	(mm)	Min	Max	Min	Max	(PsiG)	(BarG)	Nominal	Max	Nominal	Max	
GTMAX-14P60	14	60	12.63	320.8	12.73	13.19	323.3	335.0	5000	345	180	325	244	441	1" M
GTMAX-14P80	14	80	12.32	312.9	12.42	12.88	315.5	327.2	5000	345	180	325	244	441	1" M
GTMAX-14P100	14	100	11.94	303.3	12.04	12.50	305.8	317.5	5000	345	180	325	244	441	1" M
GTMAX-14P120	14	120	11.63	295.4	11.73	12.19	297.9	309.6	5000	345	180	325	244	441	1" M
GTMAX-14P140	14	140	11.32	287.5	11.42	11.91	290.1	302.5	5000	345	180	325	244	441	1" M
GTMAX-14P160	14	160	11.00	279.4	11.10	11.56	281.9	293.6	6000	414	180	325	244	441	1" M
GTMAX-16P10S	16	10S/5	15.44	392.2	15.54	16.00	394.7	406.4	3000	207	180	325	244	441	2" M
GTMAX-16P10	16	10	15.32	389.1	15.42	15.88	391.7	403.4	3000	207	180	325	244	441	2" M
GTMAX-16P20	16	20	15.20	386.1	15.30	15.76	388.6	400.3	3000	207	180	325	244	441	2" M
GTMAX-16PSTD	16	STD/30	15.07	382.8	15.17	15.69	385.3	398.5	3000	207	180	325	244	441	2" M
GTMAX-16PX5	16	40/XS	14.82	376.4	14.92	15.38	379.0	390.7	5000	345	180	325	244	441	2" M
GTMAX-16P60	16	60	14.51	368.6	14.61	15.07	371.1	382.8	5000	345	180	325	244	441	2" M
GTMAX-16P80	16	80	14.13	358.9	14.23	14.69	361.4	373.1	5000	345	180	325	244	441	1" M
GTMAX-16P100	16	100	13.76	349.5	13.86	14.32	352.0	363.7	5000	345	180	325	244	441	1" M
GTMAX-16P120	16	120	13.38	339.9	13.48	13.96	342.4	354.6	5000	345	180	325	244	441	1" M
GTMAX-16P140	16	140	12.94	328.7	13.04	13.50	331.2	342.9	5000	345	180	325	244	441	1" M
GTMAX-16P160	16	160	12.63	320.8	12.73	13.19	323.3	335.0	5000	345	180	325	244	441	1" M
GTMAX-18P10S	18	10S/5	17.45	443.2	17.55	18.01	445.8	457.5	3000	207	180	325	244	441	2" M
GTMAX-18P10	18	10	17.32	439.9	17.42	17.88	442.5	454.2	3000	207	180	325	244	441	2" M
GTMAX-18P20	18	20	17.20	436.9	17.30	17.76	439.4	451.1	3000	207	180	325	244	441	2" M
GTMAX-18PSTD	18	STD	17.07	433.6	17.17	17.63	436.1	447.8	3000	207	180	325	244	441	2" M
GTMAX-18P30	18	30	16.94	430.3	17.04	17.50	432.8	444.5	5000	345	180	325	244	441	2" M
GTMAX-18PX5	18	XS	16.82	427.2	16.92	17.38	429.8	441.5	5000	345	180	325	244	441	2" M
GTMAX-18P40	18	40	16.70	424.2	16.80	17.26	426.7	438.4	5000	345	180	325	244	441	2" M
GTMAX-18P60	18	60	16.32	414.5	16.42	16.88	417.1	428.8	5000	345	180	325	244	441	2" M
GTMAX-18P80	18	80	15.94	404.9	16.04	16.50	407.4	419.1	5000	345	180	325	244	441	2" M
GTMAX-18P100	18	100	15.51	394.0	15.61	16.07	396.5	408.2	5000	345	180	325	244	441	2" M
GTMAX-18P120	18	120	15.07	382.8	15.17	15.69	385.3	398.5	5000	345	180	325	244	441	2" M
GTMAX-18P140	18	140	14.69	373.1	14.79	15.25	375.7	387.4	5000	345	180	325	244	441	2" M
GTMAX-18P160	18	160	14.25	362.0	14.35	14.81	364.5	376.2	5000	345	180	325	244	441	2" M
GTMAX-20P10	20	10/10S/5	19.38	492.3	19.48	19.94	494.8	506.5	3000	207	180	325	244	441	2" M
GTMAX-20PSTD	20	STD/20	19.07	484.4	19.17	19.72	486.9	500.9	3000	207	180	325	244	441	2" M
GTMAX-20PX5	20	XS/30	18.82	478.0	18.92	19.38	480.6	492.3	5000	345	180	325	244	441	2" M
GTMAX-20P40	20	40	18.63	473.2	18.73	19.19	475.7	487.4	5000	345	180	325	244	441	2" M
GTMAX-20P60	20	60	18.20	462.3	18.30	18.76	464.8	476.5	5000	345	180	325	244	441	2" M
GTMAX-20P80	20	80	17.76	451.1	17.86	18.32	453.6	465.3	5000	345	180	325	244	441	2" M
GTMAX-20P100	20	100	17.26	438.4	17.36	17.88	440.9	454.2	5000	345	180	325	244	441	2" M
GTMAX-20P120	20	120	16.82	427.2	16.92	17.38	429.8	441.5	5000	345	180	325	244	441	2" M

Questions? Contact EST Group Customer Service at any of the following locations.

**CURTISS-
WRIGHT**

EST Group

www.cw-estgroup.com

North, Central & South America

EST Group Corporate Office

2701 Township Line Road

Hatfield, PA 19440-1770 USA

P: +1.215.721.1100

+1.800.355.7044

F: +1.215.721.1101

est-info@curtisswright.com

Europe / Middle East / Africa

EST Group B.V.

Hoorn 312a

2404 HL Alphen aan den Rijn

The Netherlands

P: +31.172.418841

F: +31.172.418849

est-emea@curtisswright.com

China

P +86.400.636.5077

est-china@curtisswright.cn

Singapore

P +65.3158.5052

est-asia@curtisswright.com

Part Number	Pipe Size	Pipe Schedule	Plug OD		Functional I.D. Range				Maximum Test Pressure		Installation Torque				NPT Size
					(in)		(mm)				FT-LBS		N-m		
			(in)	(mm)	Min	Max	Min	Max	(PsiG)	(BarG)	Nominal	Max	Nominal	Max	
GTMAX-20P140	20	140	16.32	414.5	16.42	16.88	417.1	428.8	5000	345	180	325	244	441	2"M
GTMAX-20P160	20	160	15.87	403.1	15.98	16.43	405.9	417.3	5000	345	180	325	244	441	2"M
GTMAX-22P10	22	10/10S/5	21.25	539.8	21.47	21.80	545.3	553.7	3000	207	180	325	244	441	2"M
GTMAX-22PSTD	22	20/STD	21.00	533.4	21.22	21.47	539.0	545.3	3000	207	180	325	244	441	2"M
GTMAX-22PXS	22	XS	20.75	527.1	20.97	21.25	532.6	539.8	5000	345	180	325	244	441	2"M
GTMAX-22P60	22	60	20.03	508.8	20.13	20.59	511.3	523.0	5000	345	180	325	244	441	2"M
GTMAX-22P80	22	80	19.53	496.1	19.63	20.16	498.6	512.1	5000	345	180	325	244	441	2"M
GTMAX-22P100	22	100	19.07	484.4	19.17	19.72	486.9	500.9	5000	345	180	325	244	441	2"M
GTMAX-22P120	22	120	18.58	471.9	18.68	19.14	474.5	486.2	5000	345	180	325	244	441	2"M
GTMAX-22P140	22	140	18.06	458.7	18.16	18.62	461.3	472.9	5000	345	180	325	244	441	2"M
GTMAX-22P160	22	160	17.55	445.8	17.65	18.11	448.3	460.0	5000	345	180	325	244	441	2"M
GTMAX-24P10	24	10/10S/5	23.31	592.1	23.47	23.74	596.1	603.0	3000	207	180	325	244	441	2"M
GTMAX-24PSTD	24	20/STD	23.00	584.2	23.22	23.47	589.8	596.1	3000	207	180	325	244	441	2"M
GTMAX-24PXS	24	XS	22.75	577.9	22.97	23.25	583.4	590.6	5000	345	180	325	244	441	2"M
GTMAX-24P30	24	30	22.63	574.8	22.84	23.14	580.1	587.8	5000	345	180	325	244	441	2"M
GTMAX-24P40	24	40	22.37	568.2	22.59	22.92	573.8	582.2	5000	345	180	325	244	441	2"M
GTMAX-24P60	24	60	21.81	554.0	22.03	22.43	559.6	569.7	5000	345	180	325	244	441	2"M
GTMAX-24P80	24	80	21.31	541.3	21.53	21.99	546.9	558.5	5000	345	180	325	244	441	2"M
GTMAX-24P100	24	100	20.72	526.3	20.82	21.45	528.8	544.8	5000	345	180	325	244	441	2"M
GTMAX-24P120	24	120	20.16	512.1	20.26	20.95	514.6	532.1	5000	345	180	325	244	441	2"M
GTMAX-24P140	24	140	19.66	499.4	19.76	20.22	501.9	513.6	5000	345	180	325	244	441	2"M
GTMAX-24P160	24	160	19.13	485.9	19.23	19.69	488.4	500.1	5000	345	180	325	244	441	2"M

Questions? Contact EST Group Customer Service at any of the following locations.

**CURTISS-
WRIGHT**

EST Group

www.cw-estgroup.com

North, Central & South America

EST Group Corporate Office
2701 Township Line Road
Hatfield, PA 19440-1770 USA
P: +1.215.721.1100
+1.800.355.7044
F: +1.215.721.1101

est-info@curtisswright.com

Europe / Middle East / Africa

EST Group B.V.
Hoor 312a
2404 HL Alphen aan den Rijn
The Netherlands
P: +31.172.418841
F: +31.172.418849

est-emea@curtisswright.com

China

P +86.400.636.5077
est-china@curtisswright.cn

Singapore

P +65.3158.5052
est-asia@curtisswright.com