

▼ ZU4204TE-Q (Pro), ZU4204BE-Q (Classic)



Z Tough, Dependable Innovative CLASS



Classic Electrical

Basic electrical package includes mechanical contactor, ON/OFF toggle switch, pendant with electro-mechanical push buttons, 24V transformer timer and operator accessible circuit breaker.

- Features Z-Class high-efficiency pump design; higher oil flow and bypass pressure, cooler running and requires 18% less current draw than comparable pumps
- Powerful 1,25 kW universal electric motor provides high power-to-weight ratio and excellent low-voltage operating characteristics
- High-strength, molded composite shroud protects motor and electrical components, while providing an ergonomic, non-conductive handle for easy transport
- Low-voltage pendant provides additional safety for the operator.

Pro-Series pump only

- LCD readout provides pressure display and a number of diagnostic and readout capabilities never before offered on a portable electric pump
- Autocycle feature provides continuous cycle operation of the torque wrench as long as the advance button is pressed (pump can be used with or without autocycle feature).



Pro-Series

Back-lit LCD and Pressure Transducer featuring Autocycle Technology.

- Torque wrench model is selectable
- “Autocycle” setting easily programmable.
- Digital read-out and “Autocycle” setting
- Pump usage information, hour and cycle counts
- Low-voltage warning and recording
- Self-test and diagnostic capabilities
- Information can be displayed in English, French, German, Italian, Spanish and Portuguese
- Pressure transducer is more accurate and durable than analog gauges
- Easy-viewing variable rate display
- Display pressure in bar, MPa or psi.



◀ Crane maintenance and assembly with S1500X wrench powered by the ZU4T-Series torque pump.



Any brand of hydraulic torque wrench can be powered by the portable ZU4T-Series torque pump. ▶



Z-Class – A Pump For Every Application

Patented Z-Class pump technology provides high by-pass pressures for increased productivity – important in applications using long hose runs and high pressure-drop circuits, like heavy lifting or certain double-acting tools.

Enerpac ZU4T-Series pumps are built to power small to large torque wrenches. Choosing the right ZU4T-Series torque wrench pump for your application is easy.

Classic Electric Torque Pumps

- The Classic has traditional electro-mechanical components (transformers, relays and switches) in place of solid-state electronics. The Classic delivers durable, safe and efficient hydraulic power.

Pro-Series Electric Torque Pumps

- Digital (LCD) display features a built-in hour meter, pressure display and shows self-diagnostic, cycle-count and low-voltage warning information. These premium features are not available on any other pump – anywhere!
- Autocycle feature provides continuous cycle operation of the torque wrench as long as the advance button is pressed (pump can be used with or without Autocycle feature).

ZU4T-Series, Torque Pump Ordering Guide

Page: 281

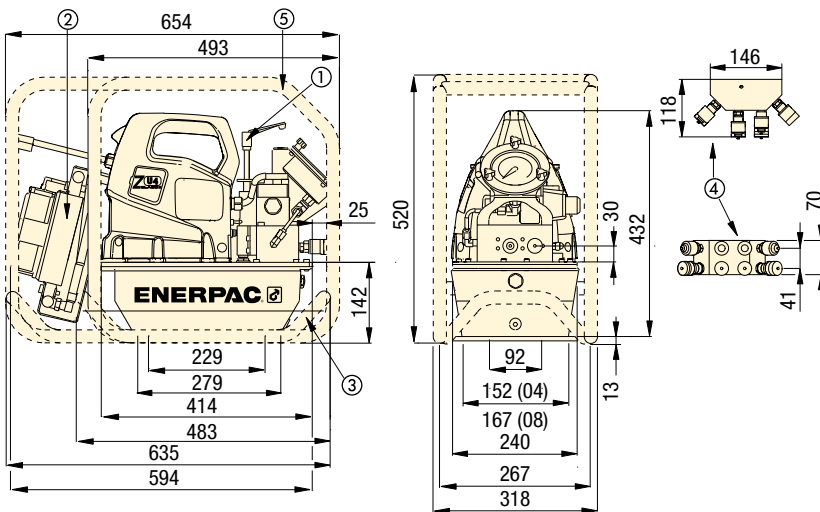

- ① User adjustable relief valve
- ② Heat Exchanger (optional)
- ③ Skid Bar (optional)
- ④ 4-wrench manifold (optional)
- ⑤ Roll Cage (optional)

ZU4T-Series Torque Pumps

Motor Size (kW)	ZU4T-Series Performance Chart				Motor Electrical Specification (Volt - Phase - Hz)	Sound Level (dBA)	Relief Valve Adjustment Range (bar)
	Output Flow Rate (l/min)						
	7 bar	50 bar	350 bar	700 bar			
1,25	11,5	8,8	1,2	1,0	115 - 1 - 50/60 208-240 - 1 - 50/60	85 - 90	124 - 700

ZU4T Series



Reservoir Capacity:
4,6 - 6,8 litres

Flow at Rated Pressure:
1,0 l/min

Motor Size:
1,25 kW

Maximum Operating Pressure:
700 bar



Bolting Integrity Software

Enerpac Bolting Integrity Software Solutions play a key role in implementing and managing an Integrity Program for bolted connections. The software offers Tool selection, Bolt Load calculations and Tool pressure settings, as well as, a combined Application Data Sheet and Joint Completion Report. Custom Joint information can also be entered.

Page: 416



Overlay Kit with Gauge

Available separately for use with ZU4T-Series Classic Pumps: GT4015Q includes gauge and torque overlays for all Enerpac torque wrenches.

OIL FLOW VERSUS PRESSURE

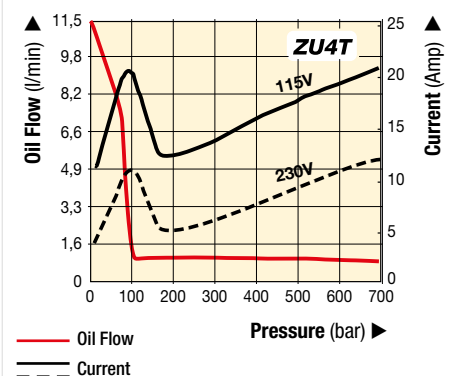



4-Wrench Manifold

- For simultaneous operation of multiple torque wrenches.



Skid Bar

- Provides greater pump stability on soft or uneven surfaces
- Provides easy two-handed lift.



Heat Exchanger

- Removes heat from the bypass oil to provide cooler operation
- Stabilizes oil viscosity, increasing oil life and reduces wear of pump and other hydraulic components.

Accessory Kit * Model Nr.	Can be used on ZU4T-Series torque pumps
ZTM-Q *	for 700 bar torque wrenches

* 4-Wrench Manifold adds 2,7 kg to pump weight.

Accessory Kit Model Nr.	Can be used on ZU4T-Series torque pumps
SBZ-4	4,6 and 6,8 litres reservoir ¹⁾
SBZ-4L	4,6 and 6,8 litres reservoir ²⁾

¹⁾ Without heat exchanger 2,2 kg.

²⁾ With heat exchanger 3,2 kg.

Accessory Kit * Model Nr.	Can be used on ZU4T-Series torque pumps
ZHE-U115	115 V pumps
ZHE-U230	230 V pumps

* Heat Exchanger adds 4,1 kg to pump weight.



Roll Cage

- Protects pump
- Provides greater pump stability.

Thermal Transfer *	Max. Pressure	Max. Oil Flow	Voltage
(Btu/h)	(bar)	(l/min)	(VDC)
900	20,7	26,5	12

* At 1,9 l/min at 21 °C ambient temperature. Do not exceed maximum oil flow and pressure ratings. Heat exchanger is not suitable for water-glycol or high water-based fluids.

▼ These rigid steel wrenches with low-profile interchangeable hexagon cassettes guarantee durability and maximum versatility in bolting applications.



Accessory Kit Model Nr.	Can be used on ZU4T-Series torque pumps
ZRC-04	4,6 and 6,8 litres reservoir ¹⁾
ZRC-04H	4,6 and 6,8 litres reservoir ²⁾

¹⁾ For pump without heat exchanger 4,3 kg.

²⁾ For pump with heat exchanger 4,3 kg.



Torque Wrench Hoses

Use Enerpac twin safety hoses to connect your torque wrench to the pump.

For 700 bar	Model Nr.
2 m long, 2 hoses	THQ702T
6 m long, 2 hoses	THQ706T
12 m long, 2 hoses	THQ712T

ZU4T-Series, Torque Pump Ordering Guide

▼ Select a pump from the model matrix at the bottom of the page.

The functionality of the pump can be determined by the model number. Utilize the guide below to select the best pump for the application.

Z	U	4	2	08	T	E	-	Q	H	M
1 Product Type	2 Motor Type	3 Flow Group	4 Valve Type	5 Reservoir Size	6 Valve Operation	7 Voltage	8 Must be Q	8 Factory Installed Accessories		

1 Product Type

Z = Pump series

2 Motor Type

U = Universal electric motor

3 Flow Group

4 = 1,0 l/min @ 700 bar

4 Valve Type

2 = Torque wrench valve

5 Reservoir Size

04 = 4,6 litres

08 = 6,8 litres

6 Valve Operation

T = **Pro-Series pump** with solenoid valve and pendant, LCD Electric and pressure transducer

B = **Classic Electric pump** with solenoid valve and pendant.

7 Voltage

B = 115V, 1 ph, 50/60 Hz

E = 208-240V, 1 ph, 50/60 Hz (with European plug CE RF compliant)

I = 208-240V, 1 ph, 50/60 Hz (with NEMA 6-15 plug)

8 Factory installed accessories

H = Heat Exchanger

K = Skid Bar

M = 4-wrench manifold

R = Roll Cage

ZU4T Series



Reservoir Capacity:

4,6 - 6,8 litres

Flow at Rated Pressure:

1,0 l/min

Motor Size:

1,25 kW

Maximum Operating Pressure:

700 bar



Torque Pump Selection Matrix

For optimum speed and performance see the torque pump and hose selection matrix.

Page: 273

▼ ZU4T-SERIES CLASSIC TORQUE PUMP MODELS

ZU4T Classic ¹⁾ Model Numbers 230 VAC, 1 ph ²⁾	Reservoir Capacity (litres)	Factory Installed Accessories					Weight (kg)
		Heat Exchanger	Roll Cage	Skid Bar	4-Wrench Manifold	Skid	
ZU4204BE-Q (B, I)	4,6						33
ZU4208BE-Q (B, I)	6,8						35
ZU4204BE-QH (B, I)	4,6	●					40
ZU4208BE-QH (B, I)	6,8	●					39
ZU4204BE-QR (B)	4,6		●				37
ZU4208BE-QR (B)	6,8		●				39
ZU4204BE-QHR (B)	4,6	●	●				41
ZU4208BE-QHR (B, I)	6,8	●	●				44
ZU4208BE-QHK (B, I)	6,8	●		●			42
ZU4208BE-QHM (B, I)	6,8	●			●		42
ZU4208BE-QMR (B)	6,8		●		●		42
ZU4208BE-QHMR (B, I)	6,8	●	●		●		46

▼ ZU4T-SERIES PRO TORQUE PUMP MODELS

ZU4T Pro Model Numbers 230 VAC, 1 ph ³⁾	Reservoir Capacity (litres)	Factory Installed Accessories					Weight (kg)
		Heat Exchanger	Roll Cage	Skid Bar	4-Wrench Manifold	Skid	
ZU4204TE-Q (B, I)	4,6						31
ZU4208TE-Q (B, I)	6,8						34
ZU4204TE-QH (B, I)	4,6	●					35
ZU4208TE-QH (B, I)	6,8	●					38
ZU4204TE-QR (B)	4,6		●				35
ZU4208TE-QR (B)	6,8		●				38
ZU4204TE-QHR (B)	4,6	●	●				40
ZU4208TE-QHR (B, I)	6,8	●	●				42
ZU4208TE-QHK (B, I)	6,8	●		●			41
ZU4208TE-QHM (B, I)	6,8	●			●		41
ZU4208TE-QMR (B)	6,8		●		●		41
ZU4208TE-QHMR (B, I)	6,8	●	●		●		45

¹⁾ Classic Electric Pump has traditional electro-mechanical components (transformers, relays, switches) in place of solid-state electronics.

²⁾ "B" indicates pump is 115V, 1-phase, 50/60 Hz. Model number example: **ZU4204BB-QHR**.

"I" indicates pump is 208-240V, 1-phase, 50/60 Hz with NEMA 6-15 plug. Model number example: **ZU4208BI-QHR**.

³⁾ "B" indicates pump is 115V, 1-phase, 50/60 Hz. Model number example: **ZU4204TB-QHR**.

"I" indicates pump is 208-240V, 1-phase, 50/60 Hz with NEMA 6-15 plug. Model number example: **ZU4204TI-QHR**.